

目 录

一、用途.....	1
二、安全操作事项.....	1
三、操作前的注意事项.....	1
四、机器的润滑.....	1
五、针线的选用.....	2
六、机针的安装.....	2
七、换梭心套.....	2
八、绕梭心线.....	2
九、梭心的安装.....	3
十、穿面线.....	3
十一、线迹长度的调节.....	4
十二、压脚压力的调节.....	4
十三、面线张力的调节.....	4
十四、挑线簧张力及行程的调节.....	4
十五、底线张力的调节.....	5
十六、针位的调节.....	5
十七、横针距（即摆针完度）的调节.....	5
十八、机头部分油量的调节.....	6
十九、皮带罩的安装.....	6
二十、膝控部件的安装.....	6
二十一、几种缝纫方法和附件的使用.....	7
二十二、机器的维护.....	9
二十三、主要技术规格.....	9

CONTENTS

1. Application.	1
2. Secure operation.	1
3. Caution before operation.	1
4. Lubrication.	1
5. Selection of needle and thread.	2
6. Inserting of needle.	2
7. Replacing bobbin.	2
8. Thread the bobbin case.	2
9. The installation of the bobbin.	3
10. Thread surface stitches.	3
11. Adjusting stitch length.	4
12. Adjusting presser foot pressure.	4
13. Adjusting needle thread tension.	4
14. Regulate the length and tension of take--up spring.	5
15. Adjust bobbin thread tension.	5
16. Adjust needle position.	5
17. The adjustment of horizontal distance.	6
18. To mount thread winder.	6
19. Assemblage of belt cover.	6
20. Mount knee lifter.	7
21. Modes of several sewing stitch and application of accessory.	7
22. Maintain of machine.	9
23. Main specification.	9

一、用途

1. APPLICATION

该机广泛用作服装、床上用品、鞋帮、毛巾、壁毯等的薄、中、厚料曲折缝、曲折刺绣缝或直缝。

采用了高精度的机械传动和有效的膝控摆幅部件，确保了形成多种线缝的完美质量。

This series of zigzag sewing machine is used to zigzag, embroidery and lockstitch on thin, medium and thick material for garment, bed articles, shoes, towels and wall carpet.

Extra accurate mechanical transmission and knee-control swing range unit assure many kinds of perfect embroidery stitch.

二、安全操作事项

2. SECURE OPERATION

1. 操作人员须经适当培训并仔细阅读该使用说明书后，方可使用；
2. 使用机器时，安全装置必须安装齐全；
3. 当拆换机器部件（如：机针、压脚、针板、送料牙和梭心等）、穿线、岗位上无操作人员或维修工时，必须关闭电源开关或拔下电源插头；
4. 机器的维修，调整等工作必须由专业技术人员进行；
5. 电气设备的使用的必须电工或专业技术人员进行。

1) The operator should be retained, and understand this manual very well before operating.

2) All security equipments should be fixed very well while running the machine.

3) Turn off the power or draw the power off, while unfixing sew accessories (like needle, presser foot, needle plate, feed dog and bobbin case), winding thread and no operator is at the workplace the machine.

4) Maintenance and adjustment of the machine should be carried by professional technician.

5) The electricity equipment should be managed by wireman or professional technician.

三、操作前的注意事项

3. CAUTION BEFORE OPERATION

为避免机器损坏，必须彻底注意下列事项：

1. 首次使用机器时，必须彻底清洗、充分加油；
2. 检查电机电压是否正常，连接相位是否正常；
3. 上轮一定要朝操作者方向运转。

To avoid the damage of machine, do care of the following:

1) Please clean the machine thoroughly, add enough oil before first usage.

2) Check the normalcy of voltage connecting oil before first usage.

3) The upper wheel should rotate in the direction facing the operator.

四、机器的润滑(图 1、2)

4. LUBRICATION(Fig.1,2)

1. 翻开机头，向油盘注入缝纫机油至 HIGH 记号部位(图1)。

2. 当油面低于ADD OIL 记号时，应再加新油(图1)。

3. 加油后，开动机器，应看到油液连续飞溅到油窗A，说明润滑正常(图3)。

4. 所用的油在38℃时，粘度为20.0mm/s，在15℃时，浓度为0.888g/m，建议使用18号油。

1) Turn Over the machine head, Pout the oil into the oil pan tu the "HIGH" marks.

2) While the oil is howr than "ADD OLL", please poru the new oil into the oil pan.

3) Tun on the machine after pouting oil,if the oil splach on the oil window A. freautently,the lubrication is goodorder.

4) The viscosity the used oil of should be20.00mm/s when the oil temperature is 38摄氏度 The density of the used oil should be 0.888g/m when the oil temperature is 15摄氏度.

We suggest that you should use No.18 white oil.

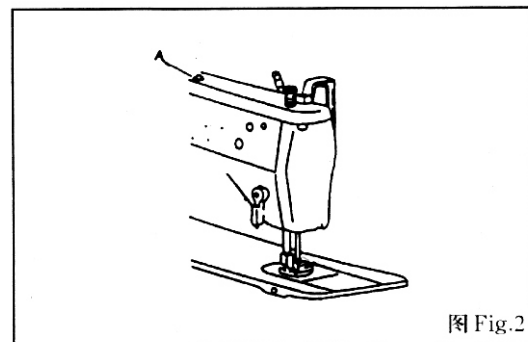
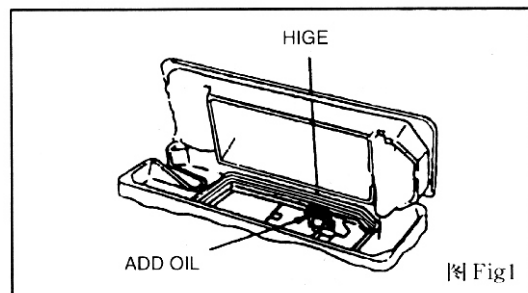

五、针线的选用

5. SELECTION OF NEEDLE AND THREAD

根据不同缝料,应选用相应合适的机针及缝线,推荐参阅表1:

表1

适用类型	薄料	中厚料	厚料
最粗针线	120	60	30
机针大于 (1/100mm)	#10	#12-#16 (80-100)	#18-#19 (110-120)
机针类型	1910-05(135x9)		
可用其他类型相当的针线			

Select the appropriate thread and needle according to the different sewing material as following:

Applicable kind of material	Thin	Medium heavy material	Heavy material
Max size of thread	120	60	30
Needle size (1/100mm)	#10	#12-#16 (80-100)	#18-#19 (110-120)
Needle type	1910-05(135x9)		
Other equal suitable size thread usable.			

六、机针的安装(图3)

6. INSERTING OF NEEDLE(Fig.3)



图 Fig.3

盘动上轮使针杆上升到最高位置, 榫开机针紧固螺钉1, 将机针柄插到顶, 长槽面向操作者, 然后, 拧紧紧固螺钉1。

Turning the hand wheel and raise the needle bar to the highest position, then loose the needle rightening screw 1. Insert the needle in the needle bar and push it up as far as it will go.

Make sure its long groove faces toward the front. Tighten needle set screw 1 securely.

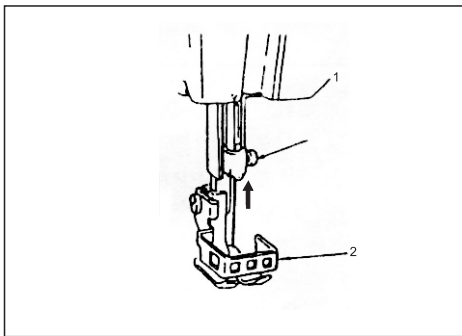
七、换梭心套(图4、5)

7. REPLACING BOBBIN CASE (Fig.4,5)



图 Fig.4



图 Fig.5

抬起梭门盖1, 即可取出梭心套2。

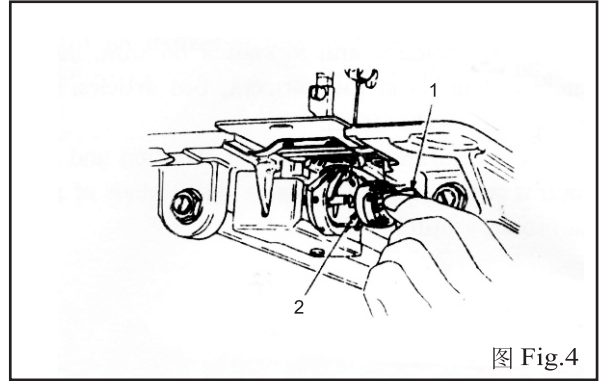
装上梭心套时, 要求先拉开梭门盖1, 将梭心套插入梭床芯轴2上。使梭心套梭门3与梭床定位槽4相扣合, 然后放下梭门盖, 紧压在梭床上, 再合上推板。

Raise latch 1. then pick out the bobbin case 2.

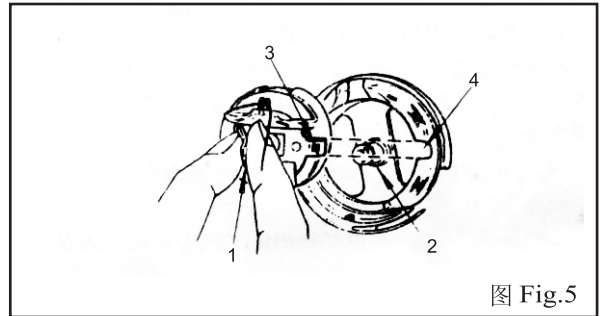
Open bed slide 1 and lay the case on the case shaft 2, while the case book 3 fit location channel 4, then down the bed slide and press the case and push the plate

八、绕旋心线

8. THREAD THE BOBBIN CASE

1. 左手抓住上轮, 右手将离合器螺钉①朝A方向转动松开。

2. 将梭心套入绕线器轴③, 尽可能地按下, 预调上夹线⑥的张力, 上夹线螺母朝+方向转动时, 张力将增大, 朝-方向转动时, 张力将减小。

3. 按箭头C方向推上绕线量调节压板②, 然后起动机绕线, 梭心将按B方向旋转。欲调节梭心上的绕线量, 先旋松调节压板螺钉④, 向操作者方向转动调节

压板, 绕线量将减少, 反之, 绕线量将增加, 调整后, 旋紧调节压板螺钉。

4. 如果绕线不均匀, 旋松螺钉⑤, 上下移动上夹线⑥使绕线均匀, 然旋紧紧螺钉⑤。

1) Stop motion of needle by loosening stop-motion screw (1). Hold hand wheel with left hand and turn stop-motion screw toward you with right hand.

2) Place bobbin on bobbin winder spindle (3), pushing it on as far as it will go.

Pre-tension (1)

+.....More tension.

-.....Less tension.

3) Push latch (2) in the direction indicated by arrow (A), then start the machine.

Bobbin winder spindle (3) rotates in the direction indicated by arrow(B).

To adjust the amount of thread on bobbin, loosen screw (4) on latch (2) and swing the latch (2) and swing the latch (2) away from you or toward you, as required.

4). For more thread on bobbin, swing latch (2) away from you.

For less thread on bobbin, swing latch (2) toward you, if thread winds unevenly on bobbin, loosen screw (5) and move pre-tension (6) up or down, as required, and tighten screw (5).



图 Fig.6

九、梭心的安装(图 7、8、9、10)

9. THE INSTALLATION OF THE BOBBIN (Fig. 7,8,9,10)

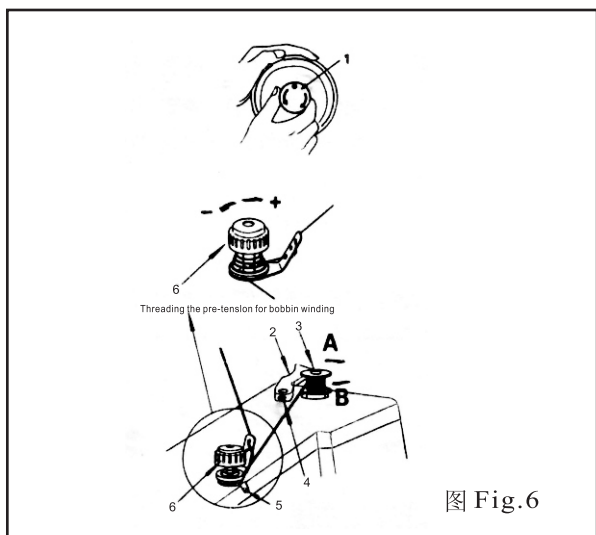

图 Fig.7



图 Fig.8

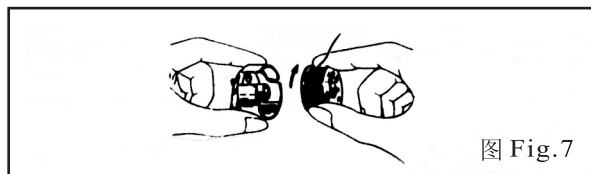

图 Fig.9

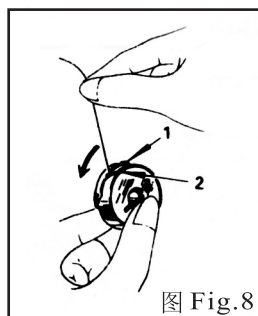

图 Fig.10

1.梭心装入梭心套(图7), 将线从长槽2及梭皮1拉出(图8)

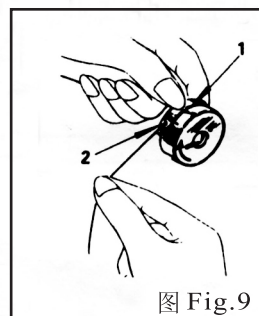
2.将线拉出梭皮末端和孔2(图9)

3.把线穿过过线孔1,留出60毫米长的线头(图10)。

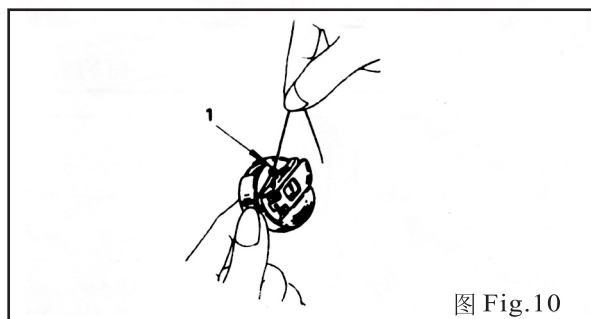
1). Put the bobbin into bobbin case. Pull thread into notch 1 and draw it under tension spring 2.(Fig.7)

2). Draw thread out from slot 2 on end of spring 1.(Fig.9)

3). Pass it through bobbin case thread guide (1), allow about 60mm of thread out of the bobbin. (Fig.10)

十、穿面线(图 11、12、13、14)

10. THREAD SURFACE STITCHES (Fig. 11, 12, 13, 14)



图 Fig.11



图 Fig.12

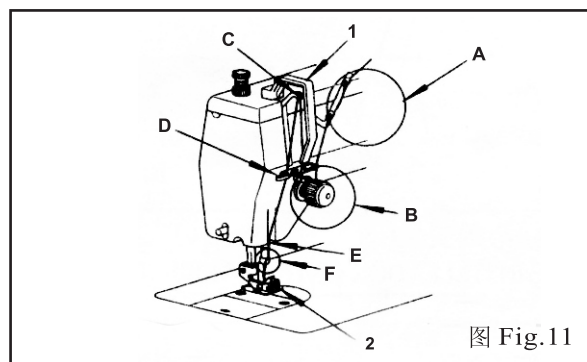

图 Fig.13

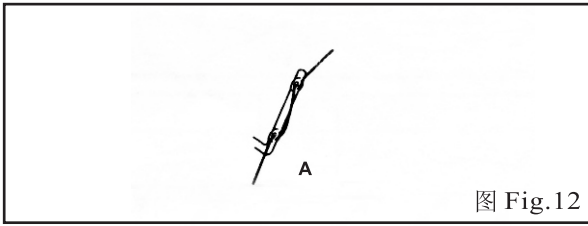

图 Fig.14

1. 针杆调到最高位置, 然后从线架上引出线头, 依次穿过 A、B、C、D、E 和 F。

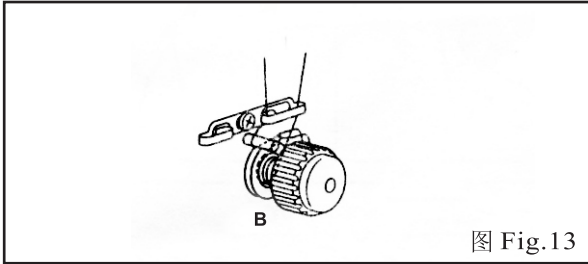
2. 如图 14 由前向后穿线。

3. 引由长 100 毫米左右的线头。

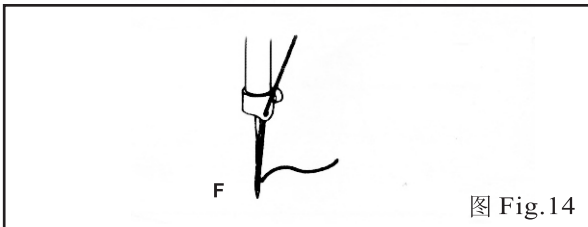
1). Raise needle bar to the highest position, then pull the thread out and through A,B,C,D,E and F.

2). As Fig.14, thread form forward to back.

3). Pull about 100mm of thread out.

十一、线迹长度的调节 (图15)

11. ADJUSTING STITCH LENGTH (Fig.15)

(1) 直线缝线迹长度 (即 针距) 调节



图 Fig.15

按顺时针或逆时针方向旋转针距旋钮1。

+..... 针距 变长;

-..... 针距 变短。

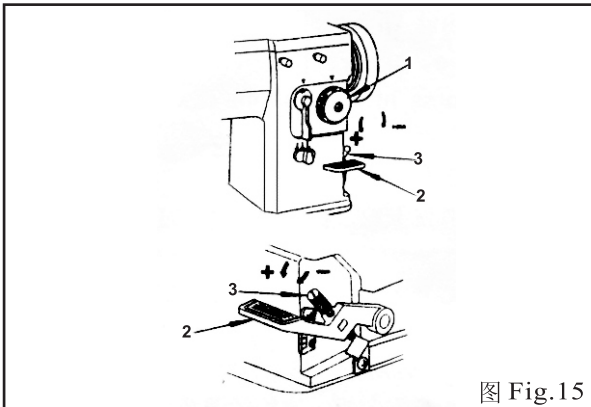
(2) 倒顺送料的调节

当倒顺扳手2处于自由状态时, 机器处于顺进料的状态。

当按下倒须扳手 2, 机器处于倒送料状态。

按顺时针或逆时针方向旋转止旋螺钉3, 可调节倒送料的针距长度。

+..... 针距 变长;

-..... 针距 变短。

Regulating the stitch length

To regulate the stitch length, turn feed regulating dial 1 toward left right as required,

+.....to lengthen

-.....to shorten

Changing the reverse feed

Push lever 2, release for forward feed and down for reverse feed.

To regulate the reverse stitch length, turn thumb screw 3 toward left or right as required.

+.....to lengthen

-.....to shorten

十二、压脚压力的调节(见图 16)

12. ADJUSTING PRESSER FOOT PRESSURE (Fig. 16)

顺时针旋转调压螺钉 1, 压力增大。

逆时针施转调压螺钉1, 压力减小。

To regulate the presser foot pressre, turn pressure regulating screw 1, toward left to strengthen or right to reduce pressure.



图 Fig.16

十三、面线张力的调节(图17)

13. ADJUSTING NEEDLE THREAD TENSION (Fig.17)

顺时针旋转夹线螺母1, 张力增大。

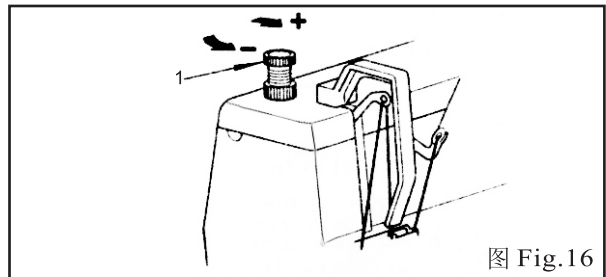
逆时针旋转夹线螺母1, 张力减小。

- +.....张力增大
-张力减小

Regulate needle thread tendion with tension regulating knob 1. toward left to strengthen or right to reduce pressure.

- +..... more tension
- less tendion



图 Fig.17

十四、挑线簧张力及行程的调节 (图18)

14. REGULATE THE LENGTH AND TENSION OF TAKE-UP SPRING (Fig.18)

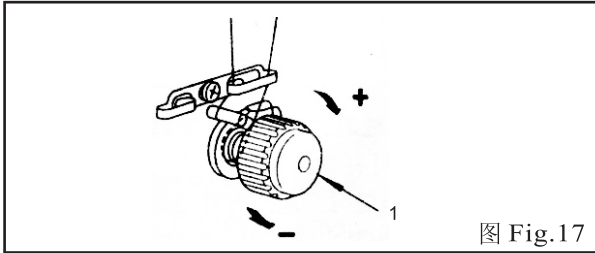

图 Fig.18

1、挑线簧张力的调节:

用螺丝刀旋转夹线螺钉 1, 调节挑线簧的张力

- +..... 张力增大
- 张力减小

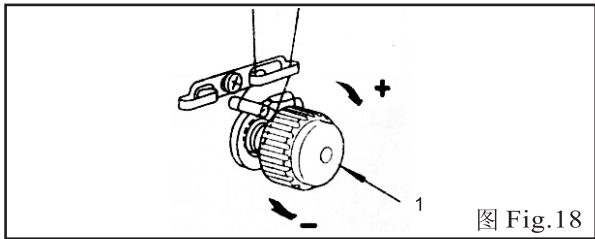
2、挑线簧行程的调节

用螺丝刀旋松夹线器紧定螺钉2, 旋转夹线器组件

3、调节挑线簧 的位置合适, 再紧固螺钉2。

1). Regulate the tension of take-up spring

Using a screwdriver in slot to regulate take-up spring tension by turning stud (1) as required.

- +.....more tendion
-less tendion

2). Regulate the length of take-up spring

To adjust the amount of take-up spring movement, loosen screw 2 and set take-up spring height by turning the entire tendion assembly 3 toward left or right, Then securely tighten screw 2 .

十五、底线张力的调节 (图19)

15. ADJUST BOBBIN THREAD TENDION (Fig. 19)

松开螺钉2,旋转底线梭皮螺钉1, 调节底线张力。

- +..... 张力增大
- 张力减小

Regulate bobbin thread tension regulating screw1.

- +.....more tension
-less tension



图 Fig.19

十六、针位的调节 (图 20)

16. ADJUST NEEDLE POSITION (Fig.20)

此类机器机针左、中、右位置的调节法, 直缝与曲折缝均相同。只要将左、中、右定位于手柄移至想要的位置, 即可缝出相应的线迹。

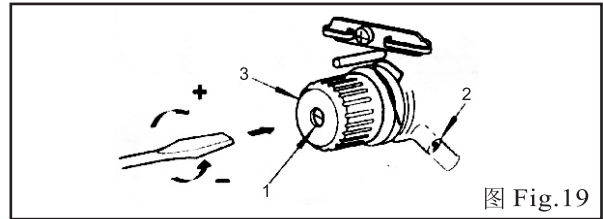
注意: 机针下有缝料时, 不可调整针位。

Left, Center and Right needle position settings are available for placement of both straight and zigzag stitching.(Fig20)

To position, push lever in and move to desired setting.

Do not make any needle position adjustment while the needle is in the fabric.



图 Fig.20

十七、横针距(即摆针宽度)的调节 (图 21)

17. THE ADJUSTMENT OF HORIZONTAL DISTANCE (Fig.21)

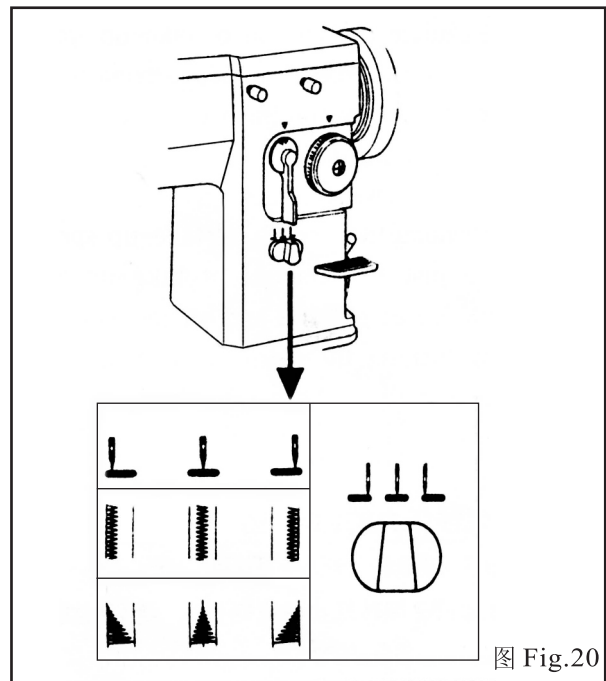
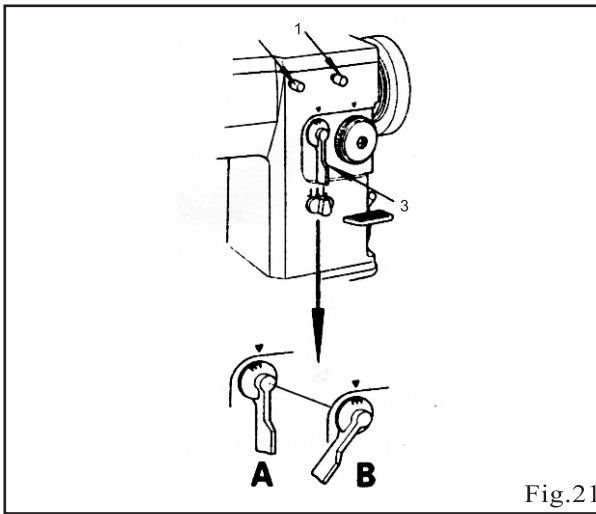

当需要调出曲折缝的横针距某一定值时，可按下面方法进行：

- (1) 松开摆针扳手定位螺钉 2；
- (2) 将横针扳手 3 扳至 0 位（即 A 位置）；
- (3) 锁紧摆针定位螺钉 2；
- (4) 松开摆针定位螺钉 1；
- (5) 顺时针旋转横杆扳手 3 至 B 位置；
- (6) 再锁紧摆针定位螺钉 1。

If one fixed value between the min-max of curvilinear stitch is needed, the adjustment can be made as follows:

- 1). Release the horizontal needle set screw 2;
- 2). Turn the spanner 3 to Oposition (i.e. A position);
- 3). Lock the set screw 2;
- 4). Release the needle set screw 1;
- 5). Turn left the spanner 3 to B position;
- 6). Then lock the set screw 1.

十八、机头部分油量的调节 (图2)

18. TO MOUNT THREAD UNWINDER (Fig.22)

当需调节机头部分油量时，拿开象开塞 3 (2 油量)，用螺丝刀拧动 A 处，以调节 1 的位置，当如图位置 A 油量很大，要使油量最小时，将转动 90 度。

While adjusting the oil amount of the machine head, please take out the rubber cap 3 ("2") is oil pipe). Turn A by screw driver to adjust the position of "1". While the position is shown in the oil amount is max. If you want to decrease the oil amount. Please turn "1" around 90°.

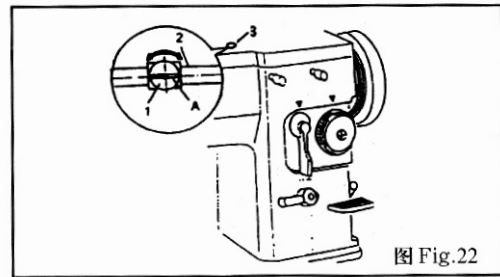

十九、皮带罩的安装 (图 23)

19. ASSEMBLAGE OF BELT COVER (Fig.23)

台板上：使手轮 V 形皮带和皮带护罩成一直线，然后拧紧螺钉。

台板下：安装皮带罩后电机轮和皮带要旋转自如。

On the table: while the V type belt is line with belt cover, tighten the screw.

Under the table: after the assemblage of belt cover the wheel and belt should rotate freely.

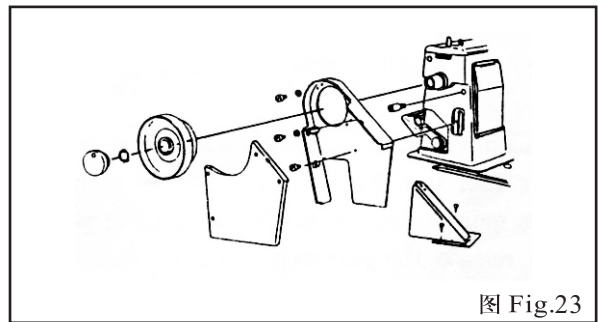

二十、膝控部件的安装 (图24)

20. MUNT KNEE LIFTER (Fig 24)

1. 压脚膝控提时的调整

1) 向左抬起压脚扳手 ⑤，使压脚 ⑥ 处于抬起状态，调节油盘下膝控部件，使 ③ 与 ① 起作用，推动足膝控板，压脚的控制高度为 9 毫米。

2. 横针膝控时的调整

1) 调节油盘下膝控部件，使 ④ 与 ② 起作用，旋松横针调节板螺钉 ⑦、⑧，使用至膝控部件到顶端，横针距达到最大值。

(1) To adjust presser lifter

Lift the presser foot ⑥ by presser lifter ⑤ and then adjust ③ and ① to push the knee lifter controller to the end, the lifting height is up to 9mm.

(2) To adjust width stitch

Adjust the knee lifter under the oil pan by ④ and ②, the loosen the adjusting screw ⑦、⑧

Push the knee lifter controller to the end, the width stitch is up to Max.

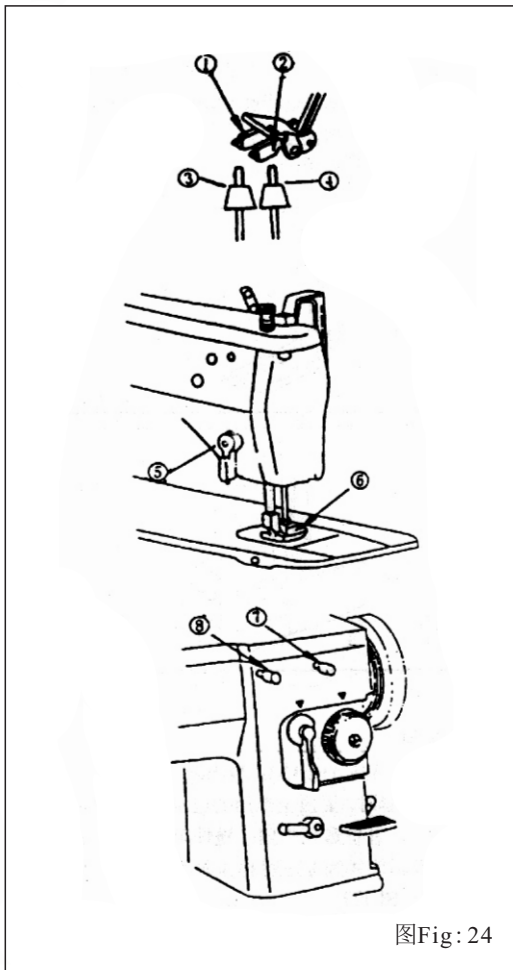

图Fig: 24

二十一、几种缝纫方法和附件的使用

20. MODES OF SEVERAL SEWING STITCH AND APPLICATION OF ACCESSORY

(20U33/43/53/63)

1. 直缝

采用专用的直缝压脚，针板与送料牙(图28)，比采用多功能压脚，针板与送料牙进行直缝，效果更佳。

进行直缝时，横针距必须调至0，采用直缝锁紧装置锁紧“针杆摆动架”，并换上专用压脚、针板、送料牙。

1. Linear sewing

In case of linear sewing, using the linear sewing presser foot, needle and feeding dog is better than using multi-function ones.(Fig.28)

While do linear sewing, the horizontal width

should be adjust to 0 position, the linear locking unit with swaying rack of locking needle shaft can be used in combination with swaying rack of locking needle shaft can be used in combination with special presser foot, needle plate and material feeding tooth.



图 Fig.25

2. 刺绣

2.Embroidery

① 必须使横针距在最小~最大之间任意调节，把直针距调至0位，并调整膝控部件(图24),使膝部控制机针的摆动。

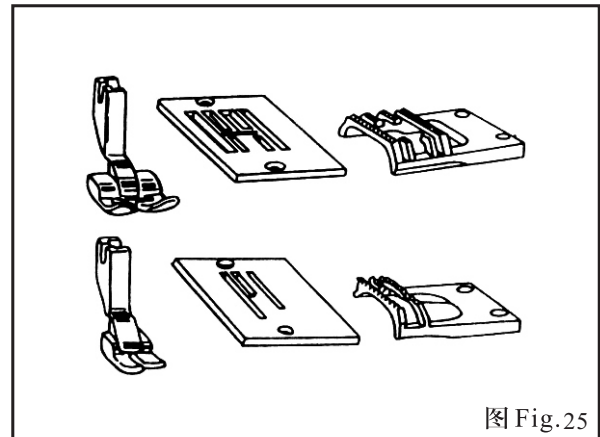
② 卸下压脚、针板和送料牙，换上绣花板。

③ 用左手捏紧面线线头，用于朝自己方向转动上轮，使底线从针板孔中拉出。

④ 确保内外绷架将缝料绷紧，否则会引起跳针，断线及缝料皱缩。(图26)

Preparation before embroidery

1). It should be noted that any free regulation can be made at the horizontal needle distance between min-max, set the vertical needle distance to 0 position and will adjust the knee-control parts to make-the component control the movement of the sway of needle.(Fig. 24)

2). Discharge the presser for and needle plate and feeding dog, then change if with embroidering plate.

3). Hold firmly the end of the surface stitches with your left hand, turn the out from the holes of the needle plate.

4). To make sure to stretchtightly the material between the internal and external embroidering frames, otherwise, maybe cause skipping and stitches breaking or material creased.(Fig. 26)



图 Fig.26

3. 拉链缝

3. ZIPPERED SEWING

该缝法采用拉链压脚 (图 27), 便于针迹接近突出的边, 并旋松螺钉 B, 调节压脚, 使机针位于压脚的左、右边槽 A 处, 可适用于图 28 中几种情况。

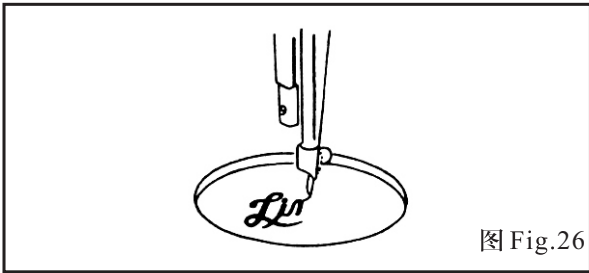
This mode is preferable to make use of zippered presser foot (see Fig.32) in a bid to make the stitches more accessible to the projecting stitches, then release the screw B, regulate the presser foot and set the needle to the presser foot and set the needle to left and right grooves A of the presser foot. The mode is expected to suit for the following sewing. (Fig.37)



图 Fig.27



图 Fig.28

4. 卷边缝

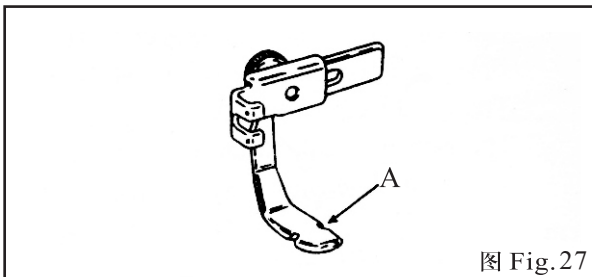
4. HEM- WRAPPING MODE

卷边缝采用卷边压脚 (图 29)

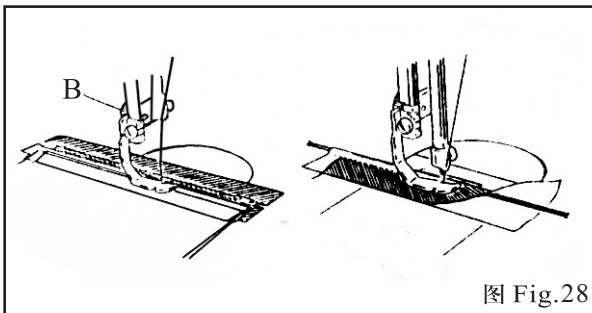
拆掉多功能压脚, 换上卷边压脚, 采用直缝法, 针位选择中间, 就可以进行图 30 的卷边缝。

In this mode, the hem-wrapping presser foot can be used as we wish (fig.29)

Remove the multi-functional presser foot and replace it with the hem-wrapping one. This is also a mode of linear sewing with the needle set to the central position; the hem-wrapping operation can be effected. (Fig.30)



图 Fig.29



图 Fig.30

5. 包梗缝

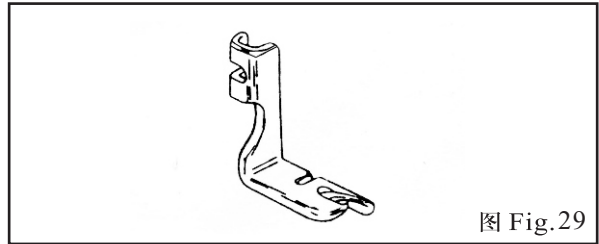
5. STEM- WRAPPING MODE

进行包梗缝时, 要换上专用的包梗压脚、针板、送料牙 (图 31), 针位选择中间, 横针距调节至 3mm 之内, 把一条较粗的线绳穿过包梗压脚的水槽 A, 就可以进行包梗缝 (图 32)。

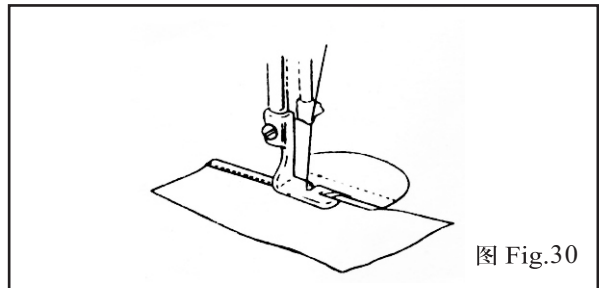
During the sewing with the stem-wrapping mode, the special stem-wrapping presser foot, needle plate and material feeding tooth should be put into use (fig.31), the needle is set to the central position and the horizontal needle distance set to 3mm, and then run the rougher thread through the small groove A on the stem-wrapping presser foot so that the sewing of this mode will be smoothly conducted.,



图 Fig: 31



图 Fig.32

装饰缝(图 33)

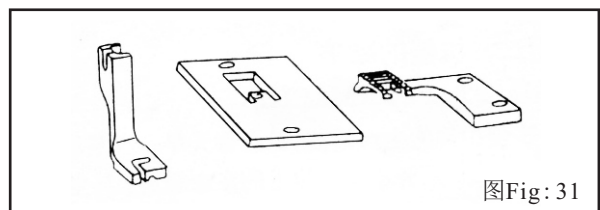
6. DECORATION SEWING(Fig.36)

只要变换左、中、右的针位及熟练控制横针距,就可缝出如图36的图案。

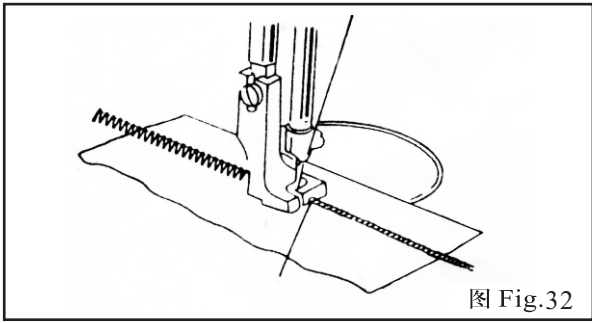
If the left, central and right needle positions can be freely changeable and the horizontal needle distance skillfully controlled, the patterns of the decoration sewing will be well achieved.



图 Fig.33

7.其他一些实用缝法(图)

7. OTHER MODES OF PRACTICAL SEWING (Fig.34)

The machine should be cleaned periodically to remove lint and fluff, which may have accumulated around the working parts. A machine in continuous use should be oiled frequently.

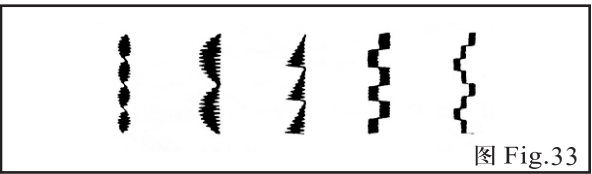

图 Fig.34

表一 ENCLOSED FIGURE:

种类 Model	针迹类型 Stitch modes	最高缝速 Max.of speed	最大横针距 Max.horizontal needle distance	最大线迹长度 Length of stitches	膝控压脚提升高度 Height of lifter
ZJ20U93	W	2000 针 / 分 2000.r.p.m	9mm	5mm	9mm

二十二、机器的维护

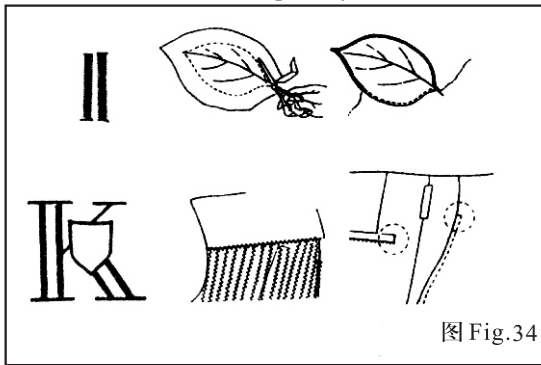
22. MAINTAIN OF MACHINE

请爱护你的生产设备,务必每天尽一次清理,除去压脚、针板、送料牙和旋梭上的多余缝屑、灰尘,经常给机器清洁、润滑。

You should protect your machine, and clean it every day. Remove lint and fluff which may have accumulated around the working parts like presser foot, needle plate, feed dog and rotating hook. A machine in continuous use should be oiled and cleaned frequently.

二十三、主要技术规格

23. MAIN SPECIFICATION

针迹类型: 见附录

机器种类: 见附录

机针规格: 见表1

手提压脚提升高度: 6.35mm

上轮: V型带轮 74mm

工作空间宽度: 211mm(20U143:289mm)

工作空间高度: 130mm

最大针距: 见附录

最高缝制速度: 见附录

The mode of stitches:see the enclosed

The mode of machine:see the enclosed

The specification of needle:see upper figure

The height of hand lifter presser foot:6.35mm

Upper wheel:model V belt wheel 74mm

The height of work:130mm

The max of needle distance:see the enclosed

The highest sewing speed:see the enclosed

零件手册

PARTS LIST

F A C E P L A C E R M T O C O V E R R M S O D E O V E R

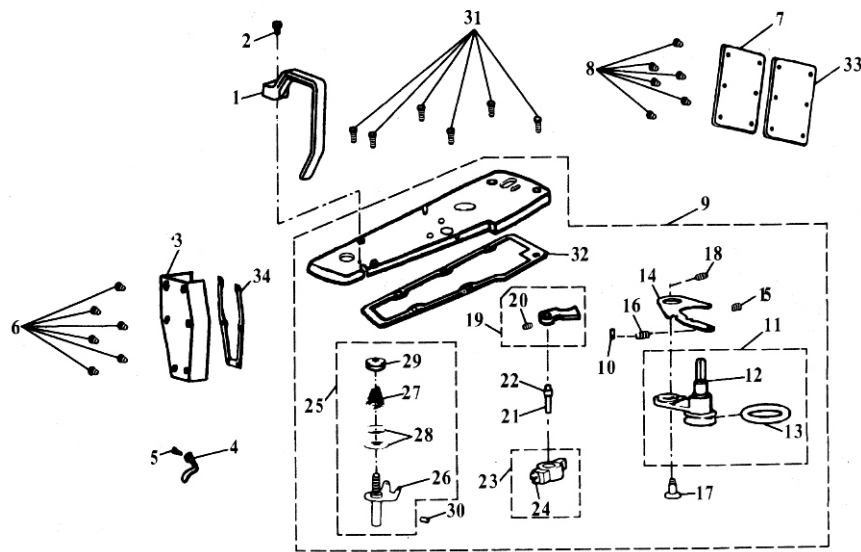

序号 NO.	型号 PART NO.	数量 QTY	名 称	DESCR I P T I O N
1	GK191-8	1	挑线杆防护罩	Thread take-up guard
2	GS378-8	1	挑线杆防护罩螺钉	Thread take-up guard screw
3	GR406/3-8	1	面板	Face plate comp
4	GW 242-8	1	线勾	Face plate thread guide
5	GS374-8	1	线勾螺钉	Face plate thread guide screw
6	GS375-8	6	面板螺钉	Face plate screw
7	GK160-8	1	后盖板	Arm side cover
8	GS132-8	6	后盖板垫片	Arm side cover set screw
9	GK187-8	1	上盖	Arm top cover comp
10	GO206-8	1	拉簧销钉	Bobbin winder bracket spacer
11	GR780/9-8	1	绕线蕊轴细件	Bobbin winder bracket comp.
12	GW 172-8	1	绕线蕊轴	Bobbin winder friction wheel spring
13	GO284-8	1	橡胶圈	Bobbin winder friction o-ring
14	GR375-8	1	绕线摆柄	Bobbin winder bracket regulating plate
15	GW 173-8	1	绕线摆柄压簧	Bobbin winder bracket regulating plate spring
16	GW 174-8	1	绕线摆柄压簧	Bobbin winder bracket spring
17	GX218-8	1	绕线曲柄销	Bobbin winder bracket hinge stud
18	GX182-8	1	绕线曲柄销螺钉	Bobbin winder bracket hinge set screw
19	GR726-8	1	绕线调节压板	Bobbin winder lever comp.
20	GS378-8	1	绕线调节压板螺钉	Bobbin winder lever set screw
21	GZ246-8	1	绕线调节轴	Bobbin winder lever stud
22	GO218-8	1	绕线调节轴挡圈	Bobbin winder lever stud ring
23	GR484/2-8	1	绕线尾位块	Bobbin winder regulating comp.
24	GS222-8	1	绕线尾位快挡圈	Bobbin winder regulating screw
25	GR778/6-8	1	上夹线器	Bobbin winder tension comp.
26	GR234/5-8	1	上过线板组件	Bobbin winder tension stud comp.
27	GW 175-8	1	上夹线簧	Bobbin winder tension spring
28	GR375-8	2	上夹线柄	Bobbin winder tension disc
29	GL175-8	1	上夹线螺母	Bobbin winder tension regulating thumb nut
30	GS275-8	1	上夹线器紧固螺钉	Bobbin winder tension set screw
31	GS680-8	6	上盖螺钉	Arm top cover screw
32	GK188-8	1	上盖垫片	Arm top cover packing
33	GK190-8	1	后盖板垫	Arm side cover packing
34	GK186-8	1	面板垫片	Face plate packing

THREAD TAKE-UP ARM ,HANDWHEEL

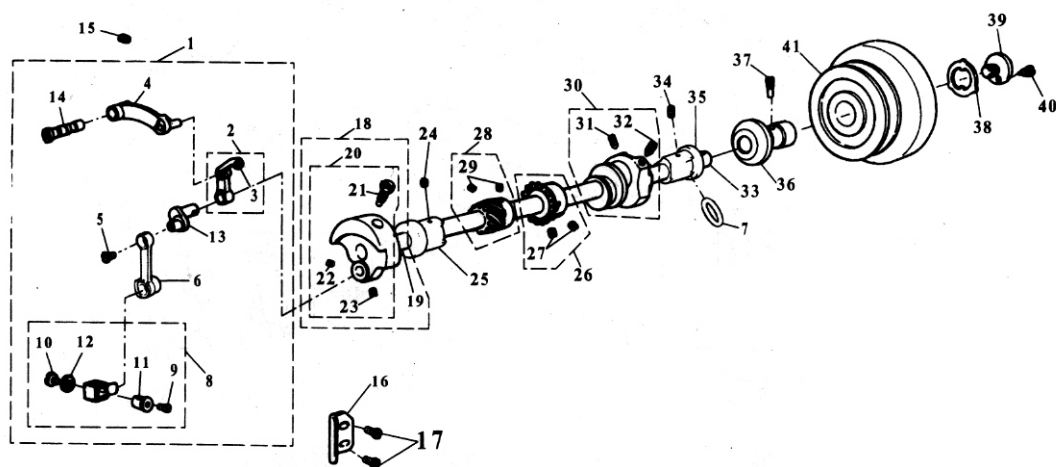

序号 NO.	型号 PART NO.	数量 QTY	名称	DESCRIPTION
1	GR1431/12-8	1	挑线杆组件	Thread take-up comp.
2	GH200-8	1	挑线杆组件	Thread take up lever with thread eye let bushing
3	GH143-8	1	挑线杆	Thread take up lever thread eye let bushing
4	GH141-8	1	挑线摇杆	Thread take up lever link
5	GS166-8	1	倒牙螺钉	Needle bar connecting link cap screw
6	GH160-8	1	小连杆	Needle bar connecting link
7	GO511-8	1	上轴后轴套O形圈	Arm shaft horizontal flanged bushing (back) O-ring
8	GR1433/5-8	1	针杆连接轴体	Needle bar connecting stud comp.
9	GS160-8	1	针杆连接轴销紧定螺钉	Needle bar set screw
10	GS161-8	1	针杆连接轴销螺钉	Needle bar connecting stud hinge pin screw
11	GZ142-8	1	针杆连接轴销	Needle bar connecting stud hinge pin
12	GO141-8	1	针杆连接轴销垫圈	Needle bar connecting stud hinge pin washer
13	GH144-8	1	针杆曲柄	Thread take up crank
14	GX144-8	1	挑线摇杆销	Thread take up lever link hinge pin.
15	GS147-8	1	挑线摇杆销螺钉	Thread take up lever link hinge pin set screw
16	GK254-8	1	小连杆导板	Needle bar connecting link guide
17	GS132-8	2	小连杆导板螺钉	Needle bar connecting link guide screw
18	GR1434/5-8	1	挑线曲柄组件	Arm shaft (horizontal) and needle bar crank comp.
19	GZ248-8	1	上轴	Arm shaft (horizontal)
20	GR1435/4-9	1	挑线曲柄	Needle bar crank comp.
21	GS168-8	1	挑线曲柄定位螺钉	Needle bar crank position screw
22	GS404-8	1	挑线曲柄紧定螺钉	Thread take up crank position screw
23	GS404-8	1	挑线曲柄紧定螺钉	Thread take up crank set screw
24	GS169-8	1	上轴前轴套螺钉	Arm shaft (horizontal) flanged bushing (front) set screw
25	GO143-8	1	上轴前轴套	Arm shaft (horizontal) flanged bushing (front)
26	GR1436/3-8	1	上轴弧齿锥齿轮	Arm shaft (horizontal) bevel gear comp.
27	GS167-8	2	上轴弧齿锥齿轮螺钉	Arm shaft (horizontal) bevel gear set screw
28	GR1437/3-8	1	上轴螺旋齿轮	Arm shaft (horizontal) worm gear comp.
29	GS170-8	2	上轴螺旋齿轮螺钉	Arm shaft (horizontal) worm gear set screw
30	GR1438-8	1	送布凸轮组件	Feed and feed lifting eccentric comp.
31	GS251-8	1	送布凸轮定位螺钉	Feed and feed lifting eccentric position screw
32	GS251-8	1	送布凸轮紧定螺钉	Feed and feed lifting eccentric rise set screw
33	GT153-8	1	送布凸轮	Feed and feed lifting eccentric ring
34	GS277-8	1	上轴后轴套螺钉	Arm shaft (horizontal) flanged bushing (back) set screw
35	GO510-8	1	上轴后轴套	Arm shaft (horizontal) flanged bushing (back)
36	GO209-8	1	上轮套筒	Clamp stop motion flanged bushing
37	GS380-8	1	上轮套螺钉	Clamp stop motion flanged gushing set screw
38	GE380-8	1	离合垫圈	Clamp stop motion clamp washer

序号 NO.	型号 PART NO.	数量 QTY	名 称	DESCRIPTION
39 40 41	GP151-8 GR279-8 GP142-8	1 1 1	离合螺钉 离合小螺钉 上轮	C lamp stop motion clamp screw C lamp stop motion stop screw Hondwheel (for motor drive)

NEEDLE BAR ,PRESSER BAR ,THROATPLATE

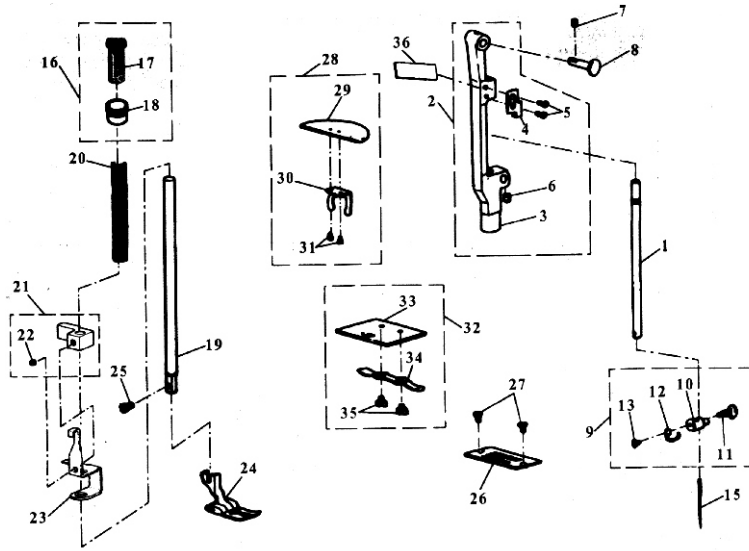

序号 NO.	型号 PART NO.	数量 QTY	名称	DESCRIPTION
1	GZ223-8	1	针杆	Needle bar hollow
2	GR485/5-8	1	针杆摆动架组件	Needle bar frame comp.
3	GR251-8	1	针杆摆动架	Needle bar frame
4	GR255-8	1	针杆定位片	Needle bar timing indicator plate
5	GS163-8	2	针杆定位片螺钉	Needle bar timing indicator plate screw
6	GS158-8	1	针杆紧定螺钉	Zigzag stitch regulator for eccentric connection pin screw
7	GS164-8	1	针杆摆动架销螺钉	Needle bar frame pin screw
8	GX143-8	1	针杆摆动架	Needle bar frame pin
9	GR484/4-8	1	针夹组件	Needle clamp comp.
10	GR467-8	1	针夹	Needle clamp
11	GS290-8	1	线勾螺钉	Needle clamp screw
12	GR466-8	1	针杆线勾	Needle clamp guard
13	GS289-8	1	机针紧定螺钉	Needle clamp guard screw
15	GV1-380	1	机针	Needle (size #14)
16	GR1440/2-8	1	调压螺钉组件	Presser regulator sub-assembly
17	GS384-8	1	调压螺钉	Presser regulator screw
18	GC178-8	2	调压螺母	Presser regulator nut
19	GZ187-8	1	压紧杆	Presser bar
20	GW153-8	1	压杆簧	Presser bar spring
21	GR1395	1	压杆导架	Presser bar guide
22	GS232-8	1	压杆导架螺钉	Presser bar guide screw
23	GR1394-8	1	挺杆导架螺钉	Presser bar guide screw
24	GR465/4-8	1	挺线定位座	Presser bar guide seat
25	GS231-8	1	压脚螺钉	Presser foot screw
26	GM156-8	1	针板	Throat plate
27	GS338-8	2	针板螺钉	Throat plate screw
28	GR477/4-8	1	针板内盖板组件	Bedplate inner cover comp.
29	GM130-8	1	针板内盖板	Bedplate
30	GW130-8	1	针板内盖板簧	Bedplate break
31	SG255-8	2	针板内盖板螺钉	Bedplate break screw
32	GR476/4-8	1	推板组件	Bedplate comp.
33	GM132-8	1	推板	Bedplate
34	GW131-8	1	推板簧	Bedplate spring
35	GM156-8	2	推板簧螺钉	Bedplate spring screw
36	GR1384-8	1	针杆摆动架毛毡	Needle bar frame felt

ZIGZAG TRIANGULAR AMC, ØØK DWANING RANK

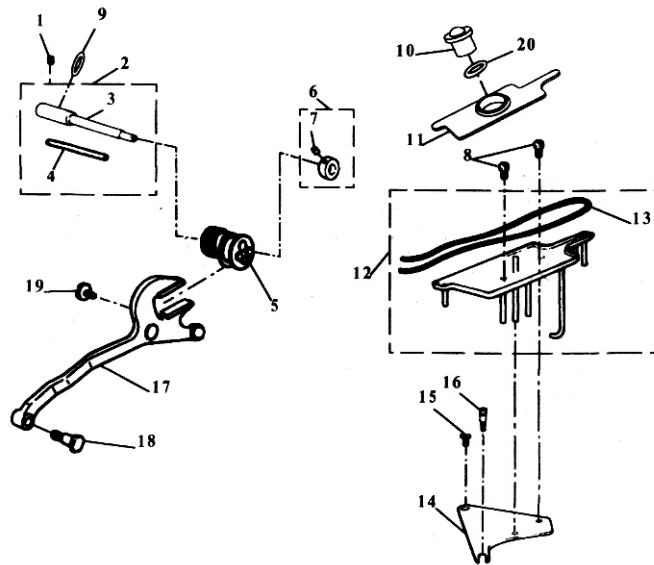

序号 NO.	型号 PART NO.	数量 QTY	名称	DESCRIPTION
1	GS147-8	1	摆针轴螺钉	Zigzag triangular cam shaft set screw.
2	GR1441/2-8	1	摆针轴组件	Zigzag triangular cam shaft comp.
3	GZ219-8	1	摆针轴	Zigzag triangular cam shaft
4	GZ221-8	1	摆针轴油线	Zigzag triangular cam shaft oil wick
5	GR145/6-8	1	摆针齿轮组件	Zigzag triangular cam shaft oil comp.
6	GR1442/3-8	1	摆针轴挡圈	Zigzag triangular cam shaft collar comp.
7	GS223-8	2	摆针轴挡圈螺钉	Zigzag triangular cam shaft collar set screw
8	GS132-8	1	小油盘螺钉	Oil reservoir set screw
9	GR1386-8	1	摆针轴 O 型圈	Zigzag triangular cam shaft o-ring
10	GR1386-8	1	油窗	Oil gauge window
11	GR1390-8	1	小油盘上盖	Oil reservoir top cover
12	GR1387-8	1	小油盘组件	Oil Reservoir comp.
13	GR1391-8	1	小油盘油线	Oil reservoir oil wick
14	GK195-8	1	小油盘安装板	Oil reservoir plate
15	GS256-8	1	小油盘安装板螺钉	Oil reservoir plate set screw (back)
16	GS212-8	1	拉簧螺钉	Oil reservoir plate set screw (front)
17	GR288-8	1	横针拨叉	Zigzag stitch regulator fork
18	GX155-8	1	针杆偏心销	Zigzag stitch regulator fork eccentric connection pin
19	GS291-8	1	摆针滑块螺钉	Bight amplitude side block cap screw
20	GR978-8	1	油窗 O 形圈	Oil gauge window o-ring

ZIGZAC TRIANGULAR CAM ,HOOK ADVANCING CRANK

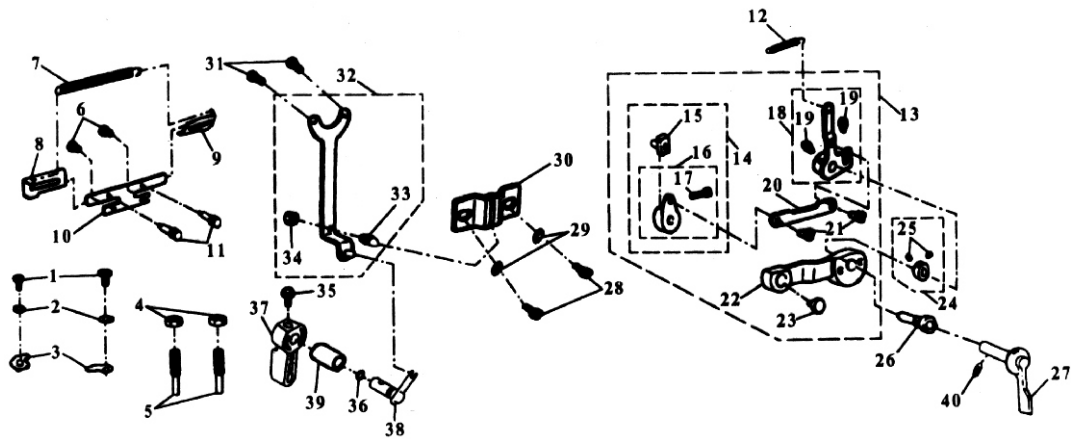

序号 NO.	型号 PART NO.	数量 QTY	名称	DESCRIPTION
1	GS 2 5 6 -	8 2	摆针针距定位块螺钉	B i g a m p l i s t t u p l e a (t l e e f r i t i g d r t e w
2	GO 1 7 4 -	8 2	摆针针距定位块垫圈	B i g a m p l i s t t u p l e a (t l e e f r i t i g d s t h e r
3	GR 2 8 9 -	8 2	摆针针距定位块	B i g a m p l i s t t u p l e a (t l e e f r t u g h t)
4	GL 1 5 3 -	8 2	摆针定位块调节螺母	B i g a m p l i s t t u p l e a (t l e e f r t u g h t)
5	GS 2 1 5 -	8 2	摆针定位块调节螺钉	B i g a m p l i s t t u p l e a (t l e e f r t u g h t)
6	GS 2 1 3 -	8 2	摆针针距定位架螺钉	B i g a m p l i s t t u p l e a (t l e e f r t u g h t)
7	GW 1 4 2 -	8 1	摆针针距定位架拉簧	B i g a m p l i s t t u p l e a (t l e e f r t u g h t)
8	GR 2 9 0 -	8 1	摆针针距调节架 (A)	B i g a m p l i s t t u p l e a (t l e e f r t u g h t)
9	GR 2 9 1 -	8 1	摆针针距调节架 (B)	B i g a m p l i s t t u p l e a (t l e e f r t u g h t)
10	GR 2 9 4 -	8 1	摆针针距定位架	B i g a m p l i s t t u p l e a (t l e e f r t u g h t)
11	GS 3 8 3 -	8 2	摆针定位螺钉	B i g a m p l i s t t u p l e a (t l e e f r t u g h t)
12	GW 1 4 1 -	8 1	摆针调节曲柄弹簧	B i g a m p l i s t t u p l e a (t l e e f r t u g h t)
13	GR 5 2 1 -	8 1	摆针定位组件	B i g a m p l i s t t u p l e a (t l e e f r t u g h t)
14	GR 5 1 9 -	8 1	摆针滑块组件	B i g a m p l i s t t u p l e a (t l e e f r t u g h t)
15	GO 1 4 0 -	8 1	摆针滑块	B i g a m p l i s t t u p l e a (t l e e f r t u g h t)
16	GR 2 9 8 -	8 1	摆针导块座	B i g a m p l i s t t u p l e a (t l e e f r t u g h t)
17	GS 1 8 5 -	8 1	摆针导块座螺钉	B i g a m p l i s t t u p l e a (t l e e f r t u g h t)
18	GR 2 9 2 /	3 - 8	摆针调节曲柄组件	B i g a m p l i s t t u p l e a (t l e e f r t u g h t)
19	GS 2 1 4 -	8 2	摆针调节曲柄螺钉	B i g a m p l i s t t u p l e a (t l e e f r t u g h t)
20	G h 1 7 8 -	8 1	摆针调节连杆	B i g a m p l i s t t u p l e a (t l e e f r t u g h t)
21	GS 2 1 6 -	8 2	差动连杆连接螺钉	B i g a m p l i s t t u p l e a (t l e e f r t u g h t)
22	GR 2 9 6 -	8 1	摆针定位块	B i g a m p l i s t t u p l e a (t l e e f r t u g h t)
23	G X 1 5 4 -	8 1	摆针导块连接销	B i g a m p l i s t t u p l e a (t l e e f r t u g h t)
24	GR 1 4 4 2 /	3 -	摆针扳手定位挡圈	B i g a m p l i s t t u p l e a (t l e e f r t u g h t)
25	GR 2 1 8 -	8 2	摆针扳手定位挡圈螺钉	B i g a m p l i s t t u p l e a (t l e e f r t u g h t)
26	GO 2 8 6 -	8 1	摆针扳手轴套	B i g a m p l i s t t u p l e a (t l e e f r t u g h t)
27	GR 7 3 1 -	8 1	摆针扳手	B i g a m p l i s t t u p l e a (t l e e f r t u g h t)
28	GS 2 7 8 -	8 2	单边曲折定位架螺钉	B i g a m p l i s t t u p l e a (t l e e f r t u g h t)
29	GO 2 1 7 -	8 2	单边曲折定位架垫圈	B i g a m p l i s t t u p l e a (t l e e f r t u g h t)
30	GR 4 6 8 -	8 1	单边曲折定位加要	B i g a m p l i s t t u p l e a (t l e e f r t u g h t)
31	GS 2 2 3 -	8 2	单边曲折调节架螺钉	B i g a m p l i s t t u p l e a (t l e e f r t u g h t)
32	GR 1 3 8 5 -	8 1	单边曲折调节架组件	B i g a m p l i s t t u p l e a (t l e e f r t u g h t)
33	GS 2 8 1 -	8 1	单边曲折定位钉	B i g a m p l i s t t u p l e a (t l e e f r t u g h t)
34	GL 1 6 3 -	8 1	单边曲折定位钉螺母	B i g a m p l i s t t u p l e a (t l e e f r t u g h t)
35	GS 3 2 2 -	8 1	单边曲折扳手螺钉	B i g a m p l i s t t u p l e a (t l e e f r t u g h t)
36	GR 6 2 1 -	8 1	单边曲折扳手轴 O 形圈	B i g a m p l i s t t u p l e a (t l e e f r t u g h t)
37	GR 6 1 9 -	8 1	单边曲折扳手	B i g a m p l i s t t u p l e a (t l e e f r t u g h t)
38	G Z 2 6 3 -	8 1	单边曲折扳手轴	B i g a m p l i s t t u p l e a (t l e e f r t u g h t)

序号 NO.	型号 PART NO.	数量 QTY	名 称	DESCRIPTION
39 40	GO 5 1 2 - 8 1 GO 4 2 0 - 8 1	1 1	单边曲折扳手轴套 摆针扳手轴O形圈	Sleeve forhd component haft O-ring of spanner of swaying needle

ARM SHAFT (UPRIGHT), ROTATING HOOK DRIVE SHAFT

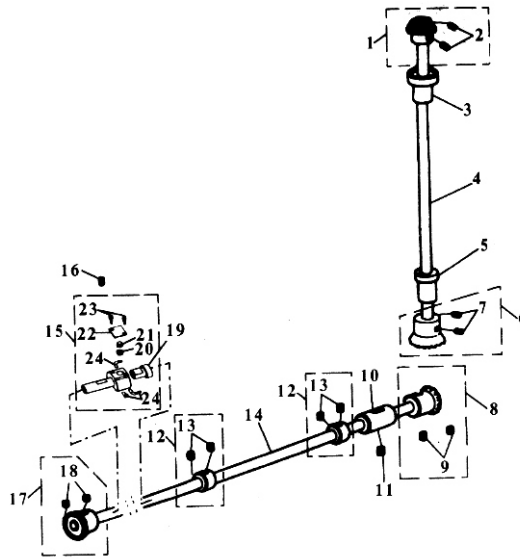

序号 NO.	型号 PART NO.	数量 QTY	名称	DESCRIPTION
1	GR1444	3	立轴弧齿锥齿轮(上)	Arm shaft (upright) bevel gear (upper) comp.
2	GS199	2	立轴弧齿锥齿轮螺钉	Arm shaft (upright) bevel gear (upper) set screw.
3	GO228	1	立轴上轴套	Arm shaft (upright) bevel gear (upper)
4	GZ224	1	立轴	Arm shaft (upright)
5	GO229	1	立轴下轴套	Arm shaft (upright) bushing (lower)
6	GR1445	3	立轴弧齿锥齿轮(下)	Arm shaft (upright) bushing (lower) comp.
7	GS199	2	立轴弧齿锥齿轮螺钉	Arm shaft (upright) bushing (lower) set screw
8	GR1446	3	下轴弧齿锥齿轮(右)	Rotating hook drive shaft screw gear (back) comp.
9	GS199	2	下轴弧齿锥齿轮	Rotating hook drive shaft screw gear (back) set screw
10	GO231	1	下轴后轴套	Rotating hook drive shaft bushing (back)
11	GS147	1	下轴后轴套螺钉	Rotating hook drive shaft bushing (back) set screw
12	GR1447	2	下轴后轴套挡圈	Rotating hook drive shaft retainer collar comp.
13	GS199	4	下轴后轴套螺钉	Rotating hook drive shaft retainer collar set screw
14	GZ225	1	下轴	Rotating hook drive
15	GO162	1	油泵组件	Rotating hook drive shaft bushing (front)
16	GS147	1	油泵紧定螺钉	Rotating hook drive shaft bushing (front) set screw
17	GR1448	3	下轴弧齿锥齿轮(左)	Rotating hook drive shaft bevel gear (front) comp.
18	GS199	2	下轴弧齿锥齿轮螺钉	Rotating hook drive shaft bevel gear (front) set screw
19	GZ168	1	油泵轴	Oil pump shaft
20	GZ269	1	油泵柱塞	Oil pump stopper
21	GW27	1	油泵柱塞弹簧	Oil pump stopper spring
22	GK198	1	油泵柱塞压板	Oil pump stopper pressure plate
23	GS688	2	油泵柱塞压板螺钉	Oil pump stopper pressure plate screw
24	GR1386	1	油泵筒管	Oil pump tube

HOOK BOBBIN CASE

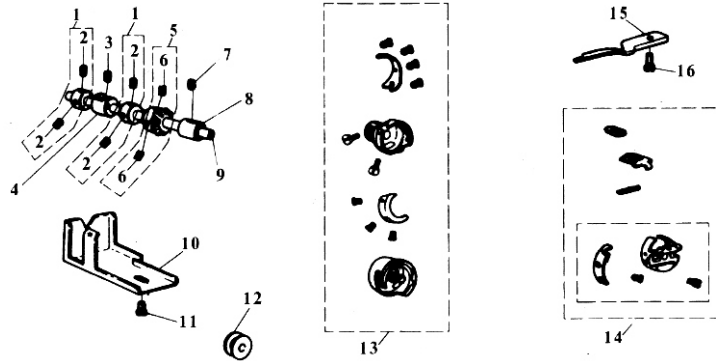

序号 NO.	型号 PART NO.	数量 QTY	名 称	DESCR IPTION
1	GR1449/3-8	2	旋梭轴挡圈	Rotating hook shaft retainer collar comp.
2	GS202-8	4	旋梭挡圈螺钉	Rotating hook shaft retainer collar screw
3	GS201-8	1	旋梭轴轴套螺钉	Rotating hook shaft bushing (shotr) setscrew
4	GO165-8	1	旋梭轴轴套	Rotating hook shaft bushing (shotr)
5	GR1450/3-8	1	旋梭轴弧齿锥齿轮	Rotating hook shaft bevel gear comp.
6	GS167-8	2	旋梭轴弧齿锥齿轮螺钉	Rotating hook shaft bevel gear set screw
7	GS201-8	1	旋梭轴前轴套螺钉	Rotating hook shaft bushing (bng) setscrew
8	GO163-8	1	旋梭轴前轴套	Rotating hook shaft gushing (bng)
9	GZ164-8	1	旋梭轴	Rotating hook shaft
10	GK130-8	1	旋梭防护罩	Rotating hook shaft bevel gear cover
11	GS132-8	1	旋梭防护罩螺钉	Rotating hook shaft bevel gear cover screw
12	GN135-8	1	梭心	Rotating hook bobbin
13	GM131-8	1	旋梭	Rotating hook
14	GN135-8	1	梭子	Rotating hook bobbin case holder comp.
15	GR278-8	1	旋梭定位板	Rotating hook bobbin case screw
16	GS256-8	1	旋梭定位板螺钉	Rotating hook bobbin case tension spring bracket
				Rotating hook bobbin holder position bracket screw

HOOK BOBBIN CASE

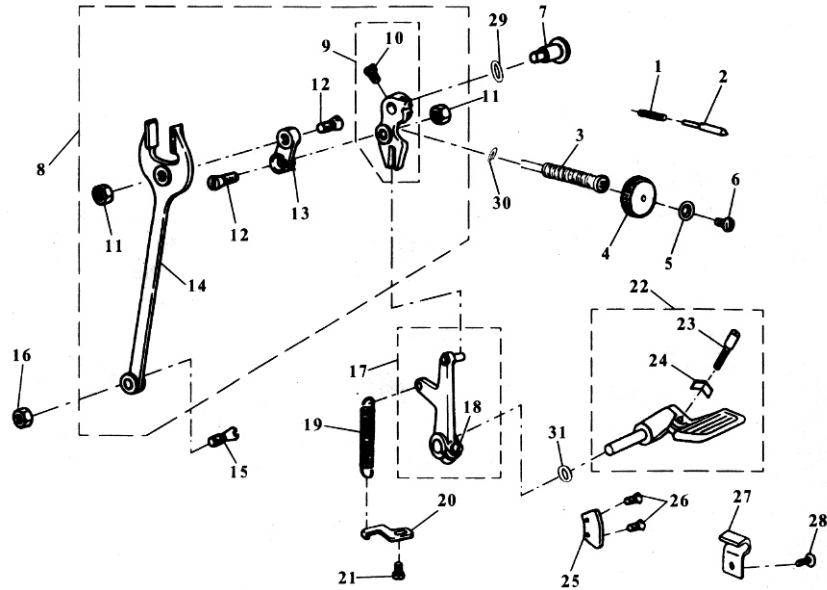

序号 NO.	型号 PART NO.	数量 QTY	名称	DESCRIPTION
1	GW 167-8	1	针距定位钉压簧	Feed guide pin spring
2	GS685-8	1	针距定位钉	Feed guide pin
3	GS684-8	1	针距调节螺钉	Feed guide pin adjusting screw
4	GR738-8	1	针距旋钮	Feed guide pin knob
5	GO380-8	1	针距旋钮螺钉垫圈	Feed guide pin knob screw washer
6	GS387-8	1	针距旋钮螺钉	Feed guide pin knob screw
7	GX302-8	1	针距座销	Feed guide pin pin
8	GR1452/2-8	1	牙叉组件	Feed forked connection comp.
9	GR1451/2-8	1	针距座	Feed guide pin
10	GS263-8	1	针距座螺钉	Feed guide pin screw
11	GC142-8	2	小圆锥螺钉	Feed connection link hinge screw
12	GS188-8	2	送布曲柄螺钉	Feed connection link hinge screw
13	GH157-8	1	针距座连杆	Feed connection link
14	GR267-8	1	牙叉	Feed forked connection
15	GS188-8	1	小圆锥螺钉	Feed forked connection hinge screw
16	GC142-8	1	小圆锥螺钉	Feed forked connection hinge screw nut
17	GR3412/2-8	1	倒针曲柄组件	Feed forked lever link comp.
18	GS142-8	1	倒针曲柄螺钉	Feed reverse lever link screw
19	GW 166-8	1	倒针复位拉簧	Feed reverse lever return spring
20	GR339-8	1	倒针复位拉簧钩	Feed reverse lever return spring bracket
21	GS256-8	1	倒针复位拉簧钩螺钉	Feed reverse lever return spring bracket screw
22	GR735-8	1	倒针扳手组件	Feed reverse lever screw
23	GS1453/3-8	1	倒针调节螺钉	Feed reverse lever adjusting screw
24	GW 200-8	1	倒针调节挡板	Feed reverse lever adjustment
25	GR737-8	2	倒针调节指示牌	Feed reverse lever indicator
26	GS42	1	倒针调节指示牌螺钉	Feed reverse lever indicator screw
27	GR736-8	1	倒针调节挡板	Feed reverse lever indicator screw
28	GS386-8	1	倒针调节挡板螺钉	Feed reverse lever indicator screw
29	GO814-8	1	针距座销 O 形圈	Feed guide pin pin O-ring
30	GR655-8	1	针距调节螺杆 O 形圈	Feed guide pin adjusting screw O-ring
31	GO514-8	1	倒针扳手轴 O 形圈	Feed reverse lever O-ring

FEED REGULATING DIAL, FEED REVERSE LEVER

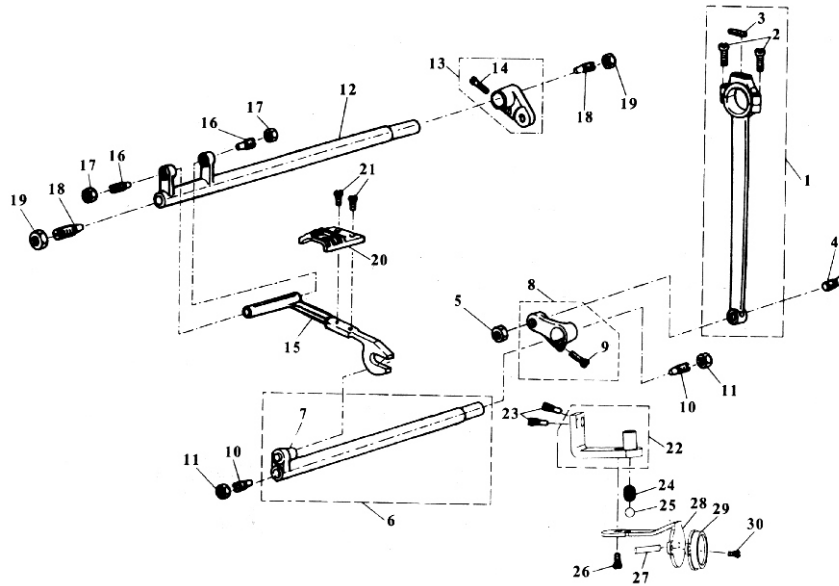

序号 NO.	型号 PART NO.	数量 QTY	名称	DESCRIPTION
1	GR504-8	1	拾牙连杆组件	Feed lifting rock shaft crank connecting rod comp.
2	GS142-8	2	拾牙连杆螺钉	Feed lifting rock shaft crank connecting rod cap screw
3	GR268-8	1	油毡	Feed lifting rock shaft crank connecting rod cap pad (felt)
4	GS188-8	1	小圆锥螺钉	Feed lifting rock shaft crank connecting rod hinge screw
5	GC142-8	1	小圆锥螺母	Feed lifting rock shaft crank connecting rod hinge screw nut
6	GR269-8	1	拾牙连杆组件	Feed lifting rock shaft comp.
7	GZ151-8	1	拾牙连杆	Feed lifting rock shaft roller and stud
8	GH1454/2-8	1	拾压曲柄	Feed lifting rock shaft crank comp.
9	GS185-8	1	拾压曲柄螺钉	Feed lifting rock shaft crank clamping screw
10	GR743-8	2	小圆锥螺钉	Feed lifting rock shaft screw center
11	GS263-8	2	小圆锥螺母	Feed lifting rock shaft screw center nut
12	GZ152-8	1	送由轴	Feed rock shaft
13	GR1455/2-8	1	送布曲柄	Feed rock shaft crank comp.
14	GS185-8	1	送布曲柄螺钉	Feed rock shaft crank clamping screw
15	GR265-8	1	牙架	Feed bar
16	GS183-8	2	牙架小顶尖螺钉	Feed bar screw center
17	GL140-8	2	牙架A顶尖螺母	Feed bar screw center nut
18	GR774-8	2	小圆锥螺钉	Feed rock shaft screw center
19	GS263-8	2	小圆锥螺母	Feed rock shaft screw center nut
20	GS160-8	1	送料牙	Feed dog
21	GS184-8	2	送料牙螺钉	Feed dog screw
22	GK199-8	1	固定架	Holding yoke
23	GS690-8	2	固定加紧螺钉	Holding yoke fastening screw
24	GW274-8	1	留珠弹簧	Roller spring
25	GO598-8	1	滚珠	Roller
26	GS688-8	1	滚珠螺钉	Roller screw
27	GR1440-8	1	吸油管	Oil suction pipe
28	GK198-8	1	滤油架	Splashing yoke of oil
29	GR1404-8	1	过滤罩	Filter sieve
30	GS687-8	1	滤油罩螺钉	Filter sieve screw

PRESSER BAR LIFTER, TENSION

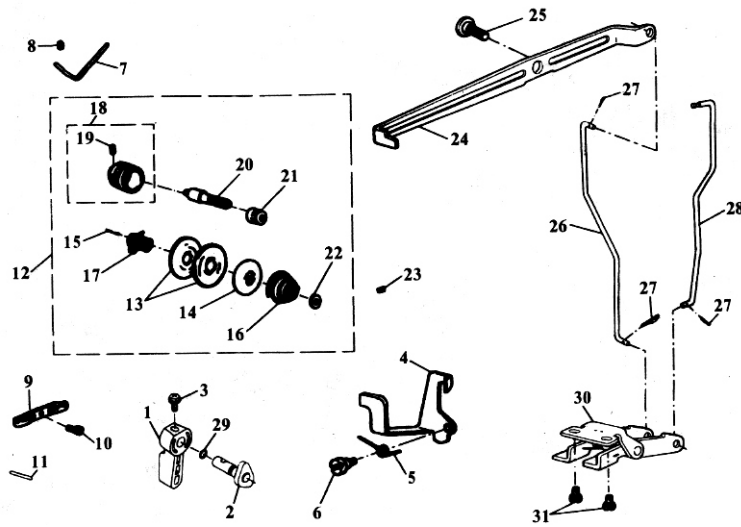

序号 NO.	型号 PART NO.	数量 QTY	名称	DESCRIPTION
1	GR619-8	1	压脚扳手	Presser bar lifter
2	GT160-8	1	压脚扳手轴	Presser bar lifter cam stud
3	GR621-8	1	压脚扳手螺钉	Presser bar lifter screw
4	GK192-8	1	松线杠杆	Tension releasing lever
5	GW 135-9	1	松线杠杆扭簧	Tension releasing lever spring
6	GS148-8	1	松线杠杆螺钉	Tension releasing lever hinge screw
7	GS379-8	1	双孔过线架	Thread retainer
8	GS139-7	1	双孔过线架螺钉	Thread retainer setscrew
9	GR231-8	1	双过线架	Thread guard (upper)
10	GS223-8	1	双过线架螺钉	Thread guard (upper) setscrew
11	GX180-8	1	过线柱	Thread guard pin
12	GR1456/11-8	1	夹线器组件	Tension comp.
13	GR237-8	2	夹线板	Tension disc
14	GR238-8	1	松线板	Tension releasing disc
15	GX132-8	1	松线钉	Tension releasing pin
16	GW 208-8	1	夹线簧	Tension spring
17	GW 131-78	1	挑线簧	Tension take-up spring
18	GR1457/2-8	1	挑线簧调节座	Tension take-up spring regulator comp.
19	GS147-8	1	夹线器紧定螺钉	Tension stud setscrew
20	GS145-8	1	夹线螺钉	Tension stud
21	GL176-8	1	夹线螺母	Tension releasing thumb nut
22	GR239-8	1	制动板	Tension releasing thumb nut washer
23	GS146-8	1	夹线器螺钉架紧定螺钉	Tension take-up spring regulator screw
24	GZ204-8	1	抬压脚杠杆	Lifting lever
25	GS235-8	1	抬压脚杠杆螺钉	Lifting lever hinge screw
26	GR323-8	1	膝提压脚杠杆	Lifting lever connecting rod
27	GS184-8	2	开口销	Lifting lever connecting rod pin
28	GZ206-8	1	膝提供针杠杆	High amplitude slide block crank knee operating connection
29	GR621-8	1	压脚扳手轴 O 形圈	Presser bar lifter cam stud o-ring
30	GR328/10-8	1	膝提杠杆座	Bell crank comp.
31	GS683-8	2	膝提杠杆座螺钉	Bell crank bracket screw

ACCESSORIES AND ATTACHMENT

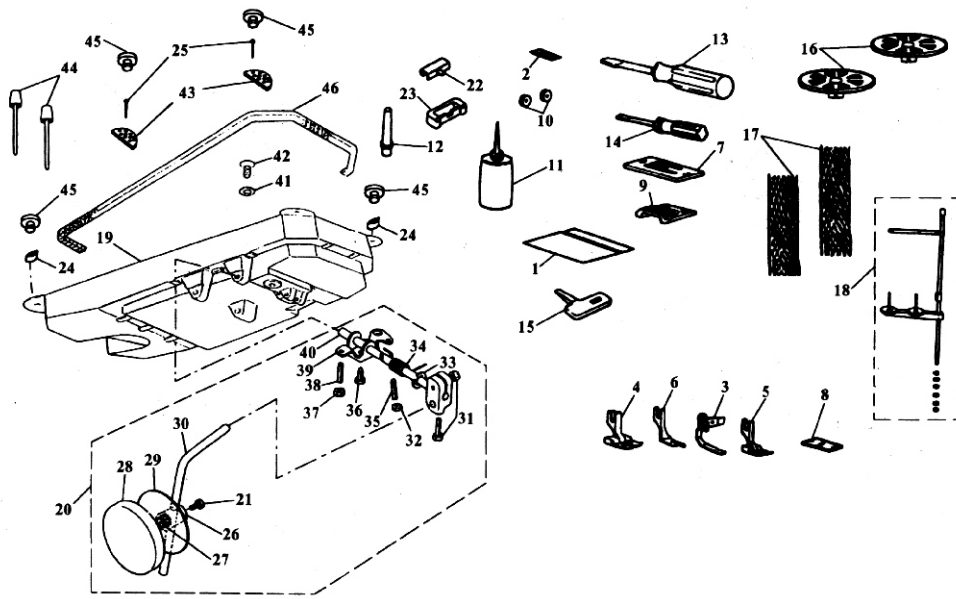

序号 NO.	型号 PART NO.	数量 QTY	名称	DESCRIPTION
1		1	线箱	Accessory box
2	GV130-8	3	机针	Needle (size #14)
3	GF109-8	1	拉链缝压脚组件	Zipper foot
4	GM172-8	1	扣眼压脚	Presser foot (spring hinged) comp. (for button holing)
5	GM1074-8	1	平缝压脚部件	Presser foot (spring hinged) comp. (for straight stitching)
6	GM108-8	1	包边压脚	Hemmer foot comp plate
7	GM104-8	1	平缝针板	Throat plate (for straight stitching)
8	GM134-8	1	绣花板	Throat plate (for embroidery)
9	GM106-8	1	平缝送料牙	Feed dog (for straight stitching)
10	FM132-8	2	梭心	Rotating hook bobbin
11	FG117-8	1	油壶	Oiler 80cc filler with singer type C-oil (for treadle operation)
12	GBR211-8	1	机头柜	Machine rest pin (for motor drive)
13	GH114-8	1	螺丝刀 (大)	Screw drive (large)
14	GF116-8	1	螺丝刀 (小)	Screw drive (small)
15	GR788-8	1	T形开刀	Screw drive (for throat plate)
16	GR789-8	2	双线团座	Thread unwinder spool cap
17	GR790-8	2	双线团	Thread unwinder spool net
18	GR760/25-8	1	双线团架组件	Thread unwinder complete (for two spools)
19	GR1397-8	1	大油盘	Drip pan
20		1	膝提组件	Control lever components
21	GS352-8	1	节头螺钉	Tip screw
22	GP142-8	2	机头连接杆	Hand wheel (for treadle operation)
23	GR696/2-8	2	连接钉座	Machine hinge
24	GR687-8	2	油盘支座	Oilpan seat
25	GBX141-8	2	操纵杆节头	Oilpan seat nail
26	GR695-8	1	操纵杆垫	Control lever tip
27	GR694-8	1	操纵杆垫	Control lever chshion
28	GR693-8	1	操纵杆软垫	Control plate
29	GR692-8	1	操纵板	Control lever
30	GR691-8	1	操纵杆	Control lever tip screw of pressure lift
31	GS358-8	2	操纵杆节头螺钉	Position adjusting nut of two-way crank
32	GL170-8	1	双向曲柄限位调节螺母	Open retaining ring of pressure lift shaft
33	GR688-8	1	插压脚轴开口挡圈	Twisting spring of two-way crank
34	GW196-8	1	双向曲柄扭簧	Two-way crank screw
35	GS357-8	1	双向曲柄限位调节螺钉	Position adjusting screw of two-way crank
36	GS356-8	1	双向曲柄螺钉	Two-way crank crank
37	GL170-8	1	双向曲柄限位调节螺钉	Position adjusting nut of two-way crank
38	GS357-8	1	双向曲柄限位调节螺钉	Position adjusting screw of two-way crank

序号 NO.	型号 PART NO.	数量 QTY	名 称	DESCR IPTION
39	GK197-8	1	抬压脚双向曲柄	Two-way crank of pressure lift
40	GZ270-8	1	抬压脚轴	Pressr lift shaft
41	54754	1	放油螺钉垫	Oil reservoir drain pulg screw gasket
42	454036-819	1	放油螺钉	Oil reservoir drain pulg screw
43	368377	1	油盘座垫	Oil pan seat cushion
44	GX305-8	2	抬压脚顶销杆	Top pin of presser lift
45	368377	4	机夹座垫	Machine head cushion
46	GR686-8	1	油盘垫	Oil pan seat cushion

ACCESSORIES AND ATTACHMENT

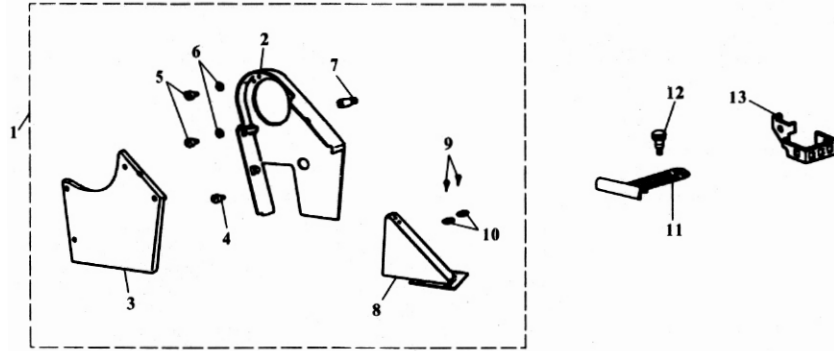

序号 NO.	型号 PART NO.	数量 QTY	名称	DESCRIPTION
1		1	防护罩组件	Beğüt a r o d m p .
2	GR 2 3 3 1	- 8	上轮罩壳	Beğüt a (r u d p p e r)
3	GR 2 3 3 0	- 8	上轮后罩壳	Beğüt a (r u d p p e r v e r)
4	GS 3 3 4 2	- 8	防护罩在螺钉	Beğüt a (r u d p p e c r r e w)
5	GS 3 3 4 3	- 8	防护罩小螺钉	Beğüt a (r u d p p e c r r e w)
6	GO 2 3 3 2	- 8	防护罩小螺针垫片	Beğüt a (r u d p p e c r r e w s h e r)
7	GS 3 3 4 4	- 8	支承螺钉	Beğüt a (r u d p p e c r r e w u d)
8	GR 2 3 3 2	- 7	皮带后罩	Beğüt a (r b o w e r)
9	GBS 2 0 4	- 8	皮带后罩安装螺钉	Beğüt a (r b o w e r i n s t a l l e r e w)
10	GBR 2 1 0	- 8	皮带后罩螺钉垫片	Beğüt a (r b o w e r i n s t a l l e r e w s h e r)
11	FM 1 0 5	- 8 1	包边挡板	C l o g t u h i d e
12	GS 6 6 5	- 8 1	包边挡板螺钉	C l o g t u h i d e u n b r e w
13	GR 1 0 0 0	- 8	保针架	F i n g e a r d